

H. W. TINGLEY.
ROTARY LATHE.

No. 488,372.

Patented Dec. 20, 1892.

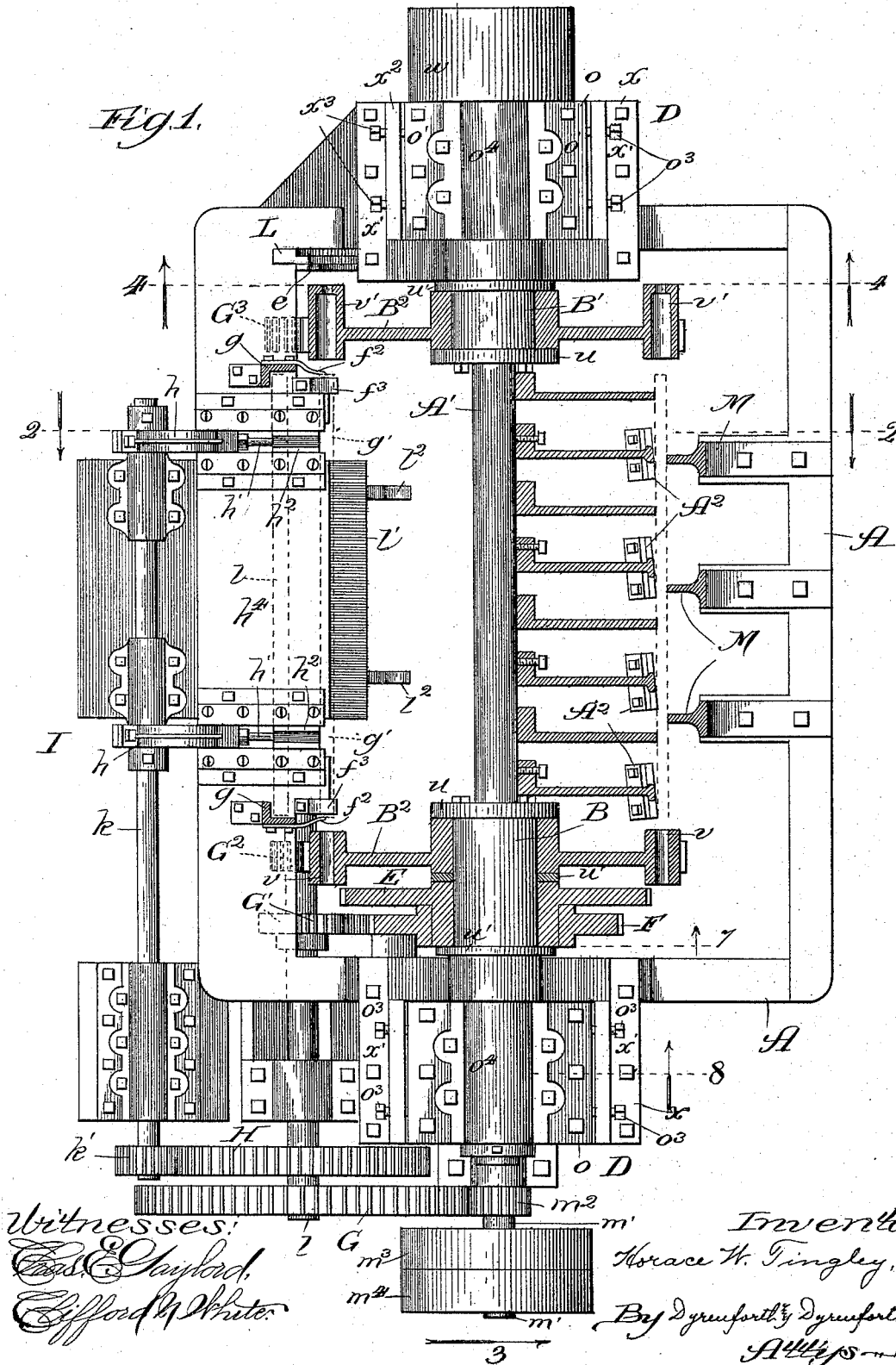

(No Model.)

6 Sheets—Sheet 2.

H. W. TINGLEY.
ROTARY LATHE.

No. 488,372.

Patented Dec. 20, 1892.

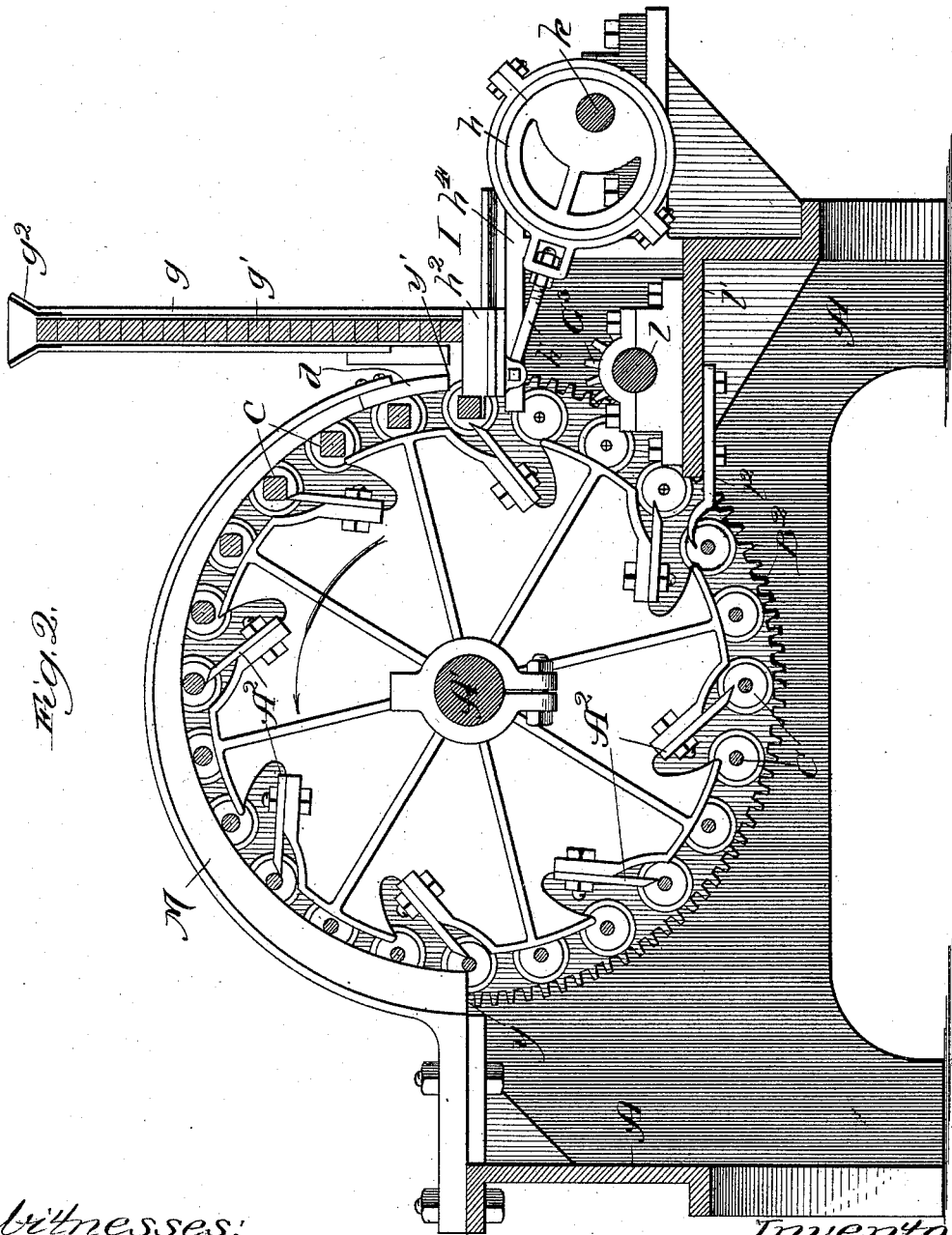

Fig. 2.

Witnesses:
Carl E. Layford.
Efford V. White.

Inventor:
Horace H. Tingley,
By Dymforth & Dymforth
Attys.

H. W. TINGLEY.
ROTARY LATHE.

No. 488,372.

Patented Dec. 20, 1892.

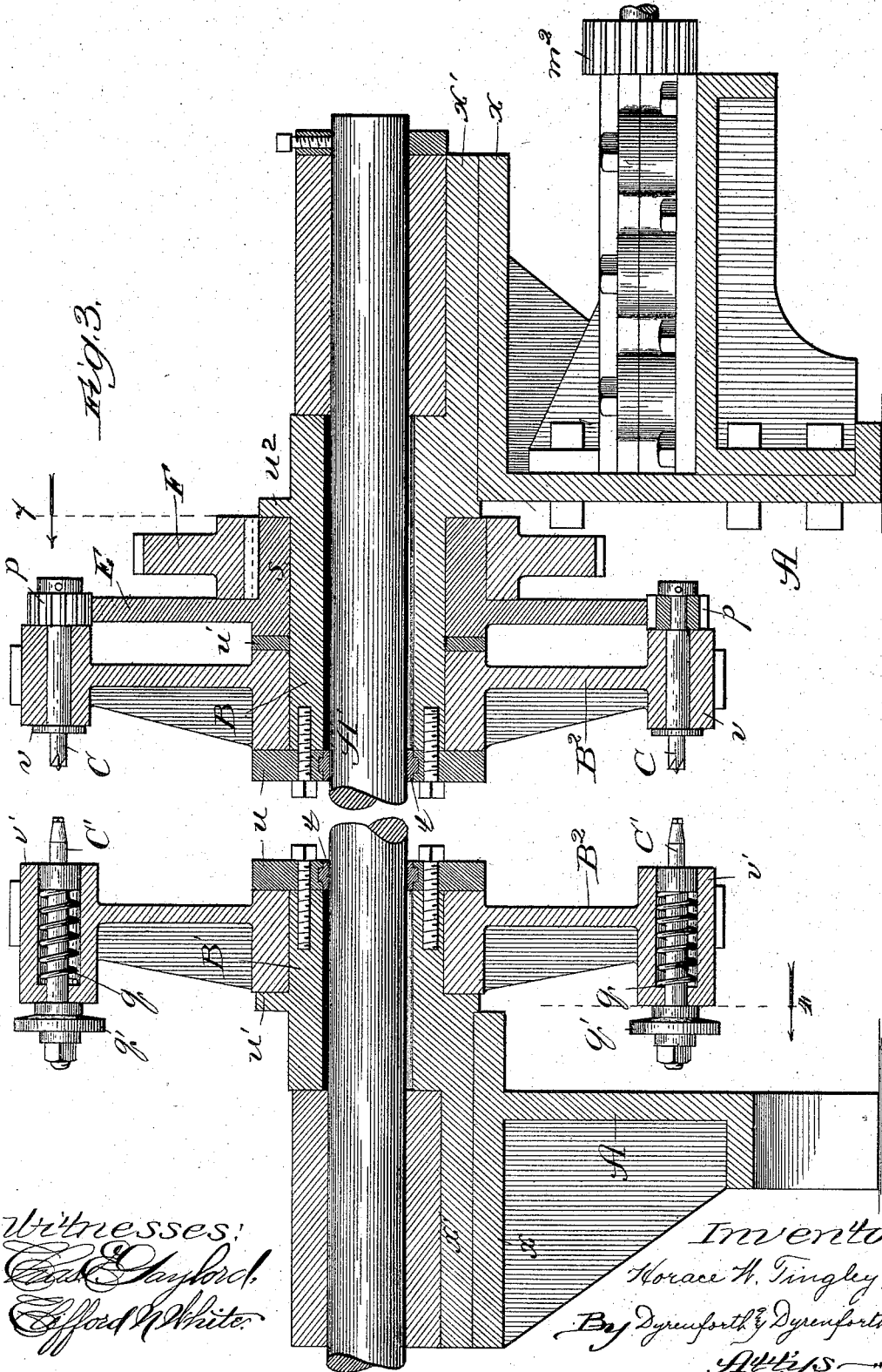

Witnesses:
Edw. D. Taylor
Edford & White

Inventor:
 Horace H. Tingley,
By Dyrenforth & Dyrenforth,
 Attys

H. W. TINGLEY.
ROTARY LATHE.

No. 488,372.

Patented Dec. 20, 1892.

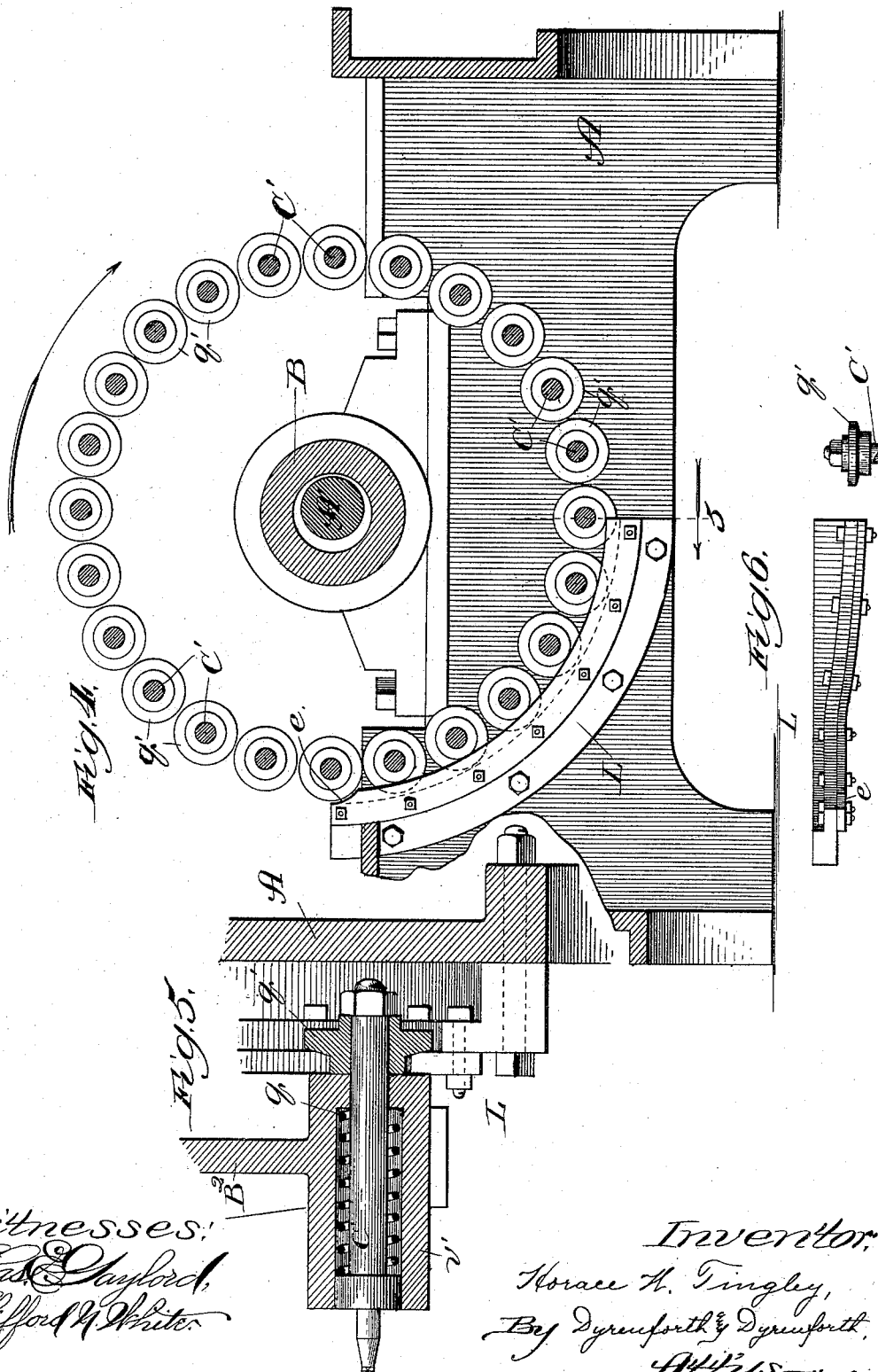

Witnesses:
Frank Gaylord,
Clifford H. White.

Inventor:
Horace H. Tingley,
 By *Dyrenforth & Dyrenforth,*
Attys.

H. W. TINGLEY.
ROTARY LATHE.

No. 488,372.

Patented Dec. 20, 1892.

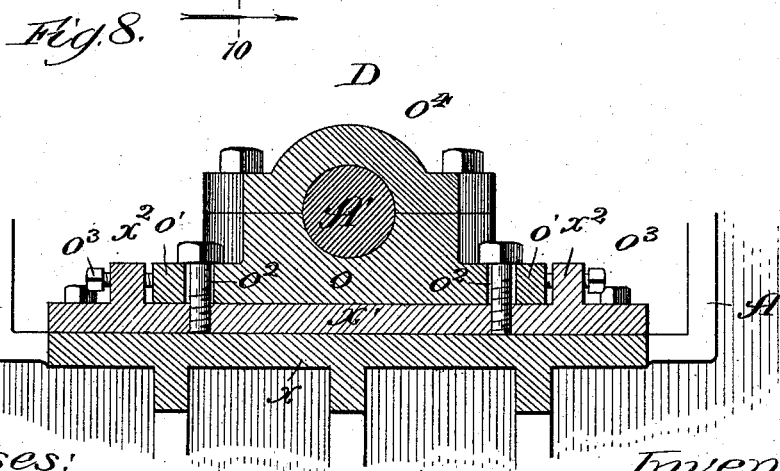
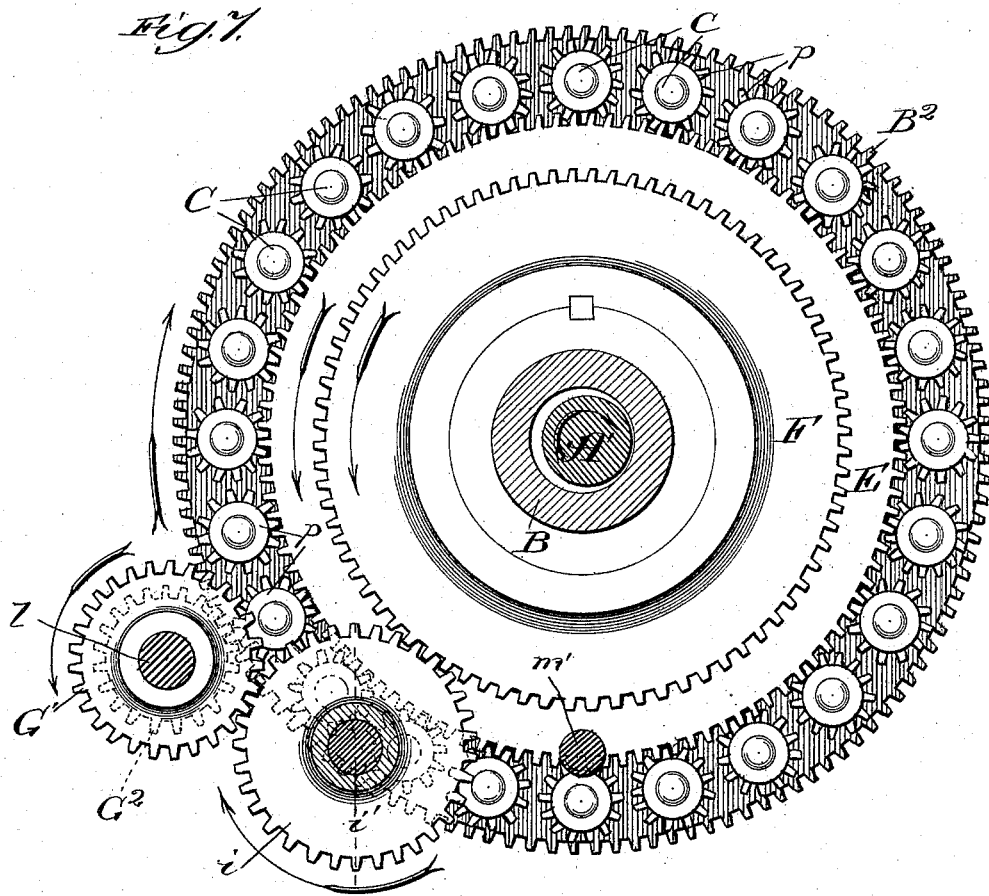

Witnesses:
Carl Chyler
Efford White

Inventor:
 Horace H. Tingley,
 By *Dyrenforth & Dyrenforth*
Attys

(No Model.)

6 Sheets—Sheet 6.

H. W. TINGLEY.
ROTARY LATHE.

No. 488,372.

Patented Dec. 20, 1892.

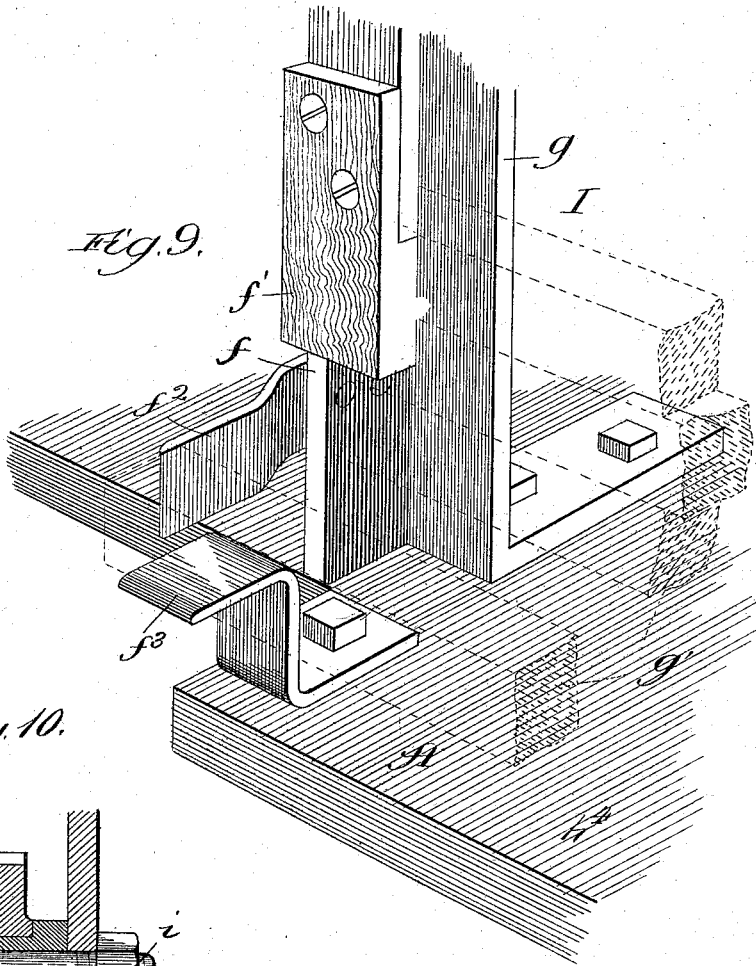

Fig. 9.

Fig. 10.

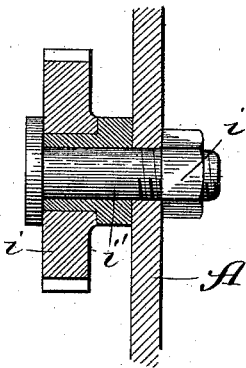
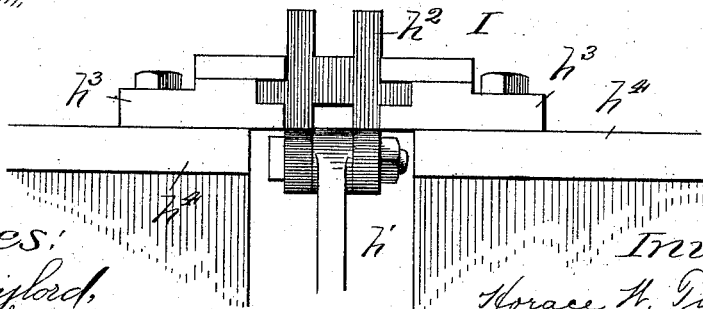

Fig. 11.



Witnesses:
Edw. C. Gaylord,
Clifford H. White.

Inventor:
Horace H. Tingley,
By Dyrenforth & Dyrenforth,
Attys.

UNITED STATES PATENT OFFICE.

HORACE W. TINGLEY, OF MICHIGAN CITY, INDIANA, ASSIGNOR TO THE
AUTOMATIC TURNING COMPANY, OF CHICAGO, ILLINOIS.

ROTARY LATHE.

SPECIFICATION forming part of Letters Patent No. 488,372, dated December 20, 1892.

Application filed April 28, 1891. Renewed June 20, 1892. Serial No. 437,344. (No model.)

To all whom it may concern:

Be it known that I, HORACE W. TINGLEY, a citizen of the United States, residing at Michigan City, in the county of La Porte and State of Indiana, have invented a new and useful Improvement in Lathes, of which the following is a specification.

My invention relates to improvements in the class of rotary lathes in which the blanks to be reduced to a predetermined form are rotated on their own axes and about rapidly rotating knives which effect the desired reduction.

My invention is especially designed as an improvement upon a lathe of the kind referred to, set forth in Letters Patent of the United States No. 429,297, dated June 3, 1890, and which, like my present device, while not limited to the production of any particular geometrical form of the work to be turned out by it, is particularly designed for turning broom-handles, for which reason I illustrate and describe it in the present connection as adapted to that particular purpose. I wish it to be clearly understood, however, that the principle embodied in my improvement is equally capable of employment, by suitable adaptation of the mechanism, for the turning of spokes and other devices involving shapes varying from the shape of a broom-handle to which the present description and drawings are confined for reasons of convenience and brevity.

A serious objection to the patented lathe referred to arises from the so-called guide-rail features forming essential parts thereof. These guide-rails, as the name implies, are relied on to control the presentation to the knives of the work to reduce the latter to the predetermined diameter; but they are found to be impracticable in the use of the lathe for manufacturing broom-handles. It is also found in the application of the lathe to the manufacture of broom-handles, that they, being produced from blanks of comparatively long and narrow dimensions and being unsupported between their ends, tend to yield to the stress of the knives against them, particularly as their rigidity decreases with the gradual reduction in diameter as the work proceeds; and that, being thus not held firmly

against the knives, the latter, especially as they become dulled, fail in their desired cooperation with the blank-carrying spindles and produce an imperfect product.

The primary object of my improvement is to provide a construction of lathe of the character referred to whereby the aforeseid objections shall be overcome. To that end I dispense with guide-rails and employ a circular path of "feed," (of course for the spindle-centers about the circle described by the knives,) eccentric with relation to the circular path of the knives. Furthermore, for holding the work unyieldingly up against the knives, I provide a desired number of what I term "steady-rests" or bearings, the same affording a back to the blanks, conforming to the exterior contour of the path of the blanks described by them while undergoing reduction.

My further object is to improve the before-mentioned patented machine in various respects, hereinafter described, thereby to render it a better machine for its purpose.

In the accompanying drawings—Figure 1 is a plan-sectional view of my improved machine, omitting, however, the blank carrying spindles, and also the cutter-heads from one side of their shaft, to avoid indistinctness in the figure. Fig. 2 is a section taken on the line 2—2 of Fig. 1 and viewed in the direction of the arrows. Fig. 3 is a broken sectional view, the section being taken at the line 3 of Fig. 1 and viewed in the direction of the arrow. Fig. 4 is a section taken either on the line 4—4 of Fig. 1 or at the line 4 of Fig. 3, and viewed as indicated by arrows. Fig. 5 is a broken view in section, the section being taken on the line 5 of Fig. 4 and regarded in the direction of the arrow. Fig. 6 is a view in the nature of a diagram illustrating a species of stationary cam-guide for withdrawing the dead-spindles to release the work when finished, one of said spindles, broken, being represented adjacent to the approach-end of the cam-guide. Fig. 7 is a section taken at the line 7 either on Fig. 1 or on Fig. 3, and viewed in the direction indicated by the arrow. Fig. 8 is a section taken at the line 8 of Fig. 1 and viewed in the direction of the arrow. Fig. 9 is an enlarged broken per-

spective view of the blank feed-hopper and spring-details for controlling each blank while being fed to the machine. Fig. 10 is a section taken on the line 10 of Fig. 7 and viewed in the direction of the arrow. Fig. 11 is a broken view in elevation showing a pusher-detail for moving the blanks successively into position, from the blank-feed, to be clamped between opposite members of a pair of the spindles.

Generally stated, the operation of the machine is as follows: The blanks are piled in a vertical feed-hopper open at its base and resting on the frame at the front of the machine. From it the blanks are fed by gravity, the lowermost dropping into position to be pushed by suitably timed mechanism between clamping-springs for holding the blank at its ends until grasped and centered between a pair of the spindles, which rotate it on its own axis against the knives and at the same time carry it around the cutter-heads through a circular feeding path eccentric to the circle described by the knives, and whereby the blank is kept close against the latter. A half-revolution around the machine of the blank suffices to finish it; and the feed-path to the knives, referred to, tapers to the end of such half-revolution, whence the finished article is carried around nearly to the insertion-point of the blank and there released on withdrawing the dead-spindle holding it.

The detailed construction is as follows: A is the frame of the machine having suitably journaled upon it the shaft A', carrying, at one end, the belt-pulley *w*, and the knives A² arranged as, or substantially in the manner, set forth in the aforesaid patent. Near opposite ends of the shaft A' it is surrounded eccentrically by sleeves B and B', forming the stationary bearings of rotary gear-wheels B² formed, respectively, with horizontally extending spindle-sockets *v* and *v'*, twenty-four of which are shown on each of the disks B², equidistant apart and coinciding in pairs on the opposite gear-wheels. Spindles C, revolvable on their own axes, or "live" spindles, carrying pinions *p* at their outer ends, are supported in the sockets *v*, and "dead" spindles C' are supported in the sockets *v'*, being longitudinally movable therein under the control of springs *q* confined around them and each having a wheel *q'* at its outer end.

The spindle-carrying gear-wheels B² are confined in place on their said bearings, as most clearly shown in Fig. 3, between heads *u* bolted to the inner ends of the sleeves and surrounding the cutter-shaft and flanges *u'* on the sleeves. The internal diameter of the sleeves B and B' is greater than the diameter of the shaft A', which is adapted to be set eccentrically with relation to the sleeves in order that the spindle-centers may be rotated through a circular path inclining from one side of the machine to the other, or another, side toward the circular plane traversed by the knives so as to compensate for the continual decrease in the diameter of each blank

under the action of the knives, by maintaining it against the latter on its way to the extremity of the described inclination, which is the finishing end of the path of the blank. The bearings D for the journaled ends of the shaft A' are adjustable to permit the desired eccentricity of the sleeves with relation to the cutter-shaft to be attained; and when properly adjusted, to afford additional bearings *t* (see Fig. 3) for that shaft, I pour around it, inside the heads *u*, Babbitt metal.

The construction of the adjustable bearings D is most clearly illustrated in Fig. 8, being provided on end-extensions *x* of the frame A to which are firmly bolted the base-extensions *x'* of the sleeve, near the opposite lateral edges of which are upward projecting flanges *x²*. The lower, or seat, portion *o* of each journal bearing is narrower than, and sits between, the flanges *x²* and is provided laterally with horizontal flanges *o'* having bolt-holes *o²* of greater diameter than the bolts which pass through them into and clamp the part *o* down upon the sleeve-extension *x'*; and in the vertical flanges *x²* are horizontal set-screws *o³* bearing at their inner ends against the sides of the flanges *o'* of the seat *o*. The cap-portion *o'* of each bearing D is fastened in place in a usual manner.

To adjust the shaft A' to bring the circular plane of the knives it carries nearer to or farther from one side of the circular plane traversed by the spindle-centers, the bolts in the holes *o²* are loosened as also the bolts *o³* at one side of the machine, when those at the opposite side are forced inward to slide the seats *o* carrying the shaft A' in the desired direction.

On the sleeve B, at the outer side of the gear-wheel B² thereon is another gear-wheel E confined at its hub *s* between the flange or ring *u'* and an outer flange *u²* to mesh with the pinions *p* on the live-spindle *v*, the adjacent wheels B² and E being adapted to revolve together. Keyed to the extended hub *s* of the wheel E, is another gear-wheel F. A counter-shaft *m* carries at its outer end a tight pulley *m³* and a loose pulley *m⁴*, and near the inner pulley a pinion *m²* meshing with a gear-wheel G on a counter-shaft *l*. The shaft *l* carries a pinion G', and also pinions G² and G³ meshing with the gear-wheels B². The shaft *l* is journaled in bearings supported on shelves *l'* (Fig. 2) adjacent to the feed, hereinafter described. Another counter-shaft *k* carries a pinion *k'* in mesh with a gear-wheel H on the shaft *l*. Between the gear-wheel F and pinion G' is an idler *i* (Figs. 7 and 10) on a stud *i'* in the frame A. The counter-shaft *k* operates feeding mechanism I: On the shaft *k* are two eccentrics *h* connected by rods *h'* with pushers *h²* supported to be reciprocated in guides *h³* on a horizontal slotted table *h⁴* (see Fig. 11). A feed-hopper *g* for the blanks *g'* is formed with two channel-irons supported vertically on the frame of the machine at opposite sides of the horizontal path of the pushers and connected by a flaring top *g²*.

The blanks, which are thus retained in the feed-hopper only at their ends, extend across the path of the pushers, which, in their forward movement, from a line behind the plane of the blanks, push the lowermost one of the pile in the hopper, into the machine, to be taken up in the manner hereinafter described, the feed being, thus, by gravity. The feed-hopper g is open at its front side near the base of each channel-iron, as indicated at f (see particularly Fig. 9) each opening f being, vertically, considerably wider than a blank g' , so as to avoid the possibility of exceptionally thick blanks being forced by the pushers, in their operation, against the front side of the hopper, which would tend to break it and disorganize the machine. To prevent more at a time than the lowest of the supply of blanks from being fed into the machine, I extend from the top of each opening f , as a continuation of the front of the channel-iron, a wooden guard f' , which should project far enough downward to overlap the second lowest of the blanks g' . Then if ever the lowermost blank be thick enough to, or should from any other cause, be overlapped by the extensions f' , the fastening of the latter is purposely so frail that they will give way under the force of the pushers and thus save any material damage to the machine.

From the outer sides of the two channel-irons of the feed-hopper g , I extend, horizontally, flat springs f^2 adapted to receive each blank as it is pushed between them by the pushers and clamp it at its ends yieldingly in position to be taken up by a pair of the spindles when the respective spring-controlled dead spindle C' is released for the purpose in the manner hereinafter explained. I furthermore provide springs f^3 on the frame A, projecting somewhat in advance of the springs f^2 and in the plane between the latter, to afford a yielding seat for each blank while held between the springs f^2 , so that if the motion of the machine, after grasping a blank, should not be sufficiently rapid to prevent the turning of the blank by the spindle from causing the rear corner of the blank to strike the seat f^3 , the latter will readily yield, and prevent injury to the adjustment of the blank between the spindles.

From below the shelves l' I extend, to project in advance of the latter, strippers l^2 , which are located at the end of the circular path of the blanks about the machine, just below the feeding-point thereof; and it is near the stripping-point that each spring-controlled spindle C' has to be withdrawn to release its blank, the strippers serving to insure the release of the blank in case it should stick. To that end I provide and secure to the inner side of the frame A, in the path of the wheels q' of the spindles C' , a cam guide-rail device L (see Figs. 4 and 6) with which the wheels q' engage successively in their rotation about the knives, and which, by guiding them outwardly, tends to effect the with-

drawal of each from its blank before the latter reaches the strippers. When a wheel q' reaches the farther end of the cam-guide L , where it is provided with an arc-shaped notch e (Fig. 4) which coincides with the adjacent end of the blank g' being held between the springs f^2 , the spring q controlling the respective spindle C' , by its recoil forces it back to its normal position and in doing so it engages the adjacent end of the blank and grasps the latter between itself and its companion live-spindle.

M (Fig. 2) is the "steady-rest" hereinbefore referred to. As represented in Fig. 1, three of the steady-rests are provided between the spindle-carrying gears B^2 . Each steady-rest M describes the arc of a circle extending from a laterally central line longitudinal of the machine, (which is the point at which the work on each blank is finished,) directly or almost directly opposite the pushers h^2 , nearly to the latter, the portion of a circle described by each device M being such as to cause it to widen with relation to the circle traversed by the spindle-centers, from its end y to its end y' in accordance with the increasing diameters of the blanks from the point where they are finished to the point at which they are fed to the machine, so that it will at every point afford a bearing for the blanks to hold them against the knives. Each steady-rest should be strong and constructed of metal, with its end y' forming an extension d of wood, frailly secured in place, so that in case of a blank g' , in feeding, (to do which it must pass under the end y' .) being accidentally forced against the steady-rests, it will only break away the extensions without liability of otherwise harming the mechanism.

As will be noticed, with relation to the circle described by the knives, the circles described by the spindle-centers and steady-rests are not only both eccentric to it but also to each other.

The operation of the machine is as follows: The shaft A' carrying the knives A^2 is driven in one direction, indicated by an arrow in Fig. 7, from the pulley w . All the rest of the mechanism is driven, independently of the cutter-shaft, from the shaft m' , which is driven, also as indicated by an arrow, in the same direction as the shaft A' . The shaft l is driven by a pinion m^2 on the shaft m' , which meshes with a gear-wheel G on the shaft l , the latter carrying a pinion G' which meshes with the idler i on the stud i' and, through the idler, drives the gear F . The counter-shaft l through the pinions G^2 and G^3 it carries, which engage the spindle-carrying gear-wheels B^2 , drives the latter in the direction opposite that in which the gear F turns. Thus the spindles C and C' are revolved about the knives A^2 in the same direction that the knives are rotated, and the spindles C are rotated on their own axes, against the direction of rotation of the knives, by meshing with the gear-wheel E , thereby revolving also the

blanks on the dead-spindles C'. A gear-wheel H meshes with the pinion k' on the counter-shaft k , thereby driving the last-named shaft to reciprocate the pushers h^2 . With blanks g' in the feed-hopper g , and the mechanism operating in the manner thus described, each forward stroke of the pushers h^2 introduces a blank between the clamping-springs f^2 just prior to the recoil of a spindle C' through the recess or notch o at the end of the cam-guide L adjacent to an end of the supported blank. When such spindle recoils, its center penetrates that end of the blank, forcing the opposite end into engagement with the center of its companion-spindle C, which revolves the blank slowly on its own axis against the knives, while carrying it, by the rotary motion of the gears B², around the knives toward the point y of the steady-rests where the blank, having made a half-revolution about the machine, will be furnished, meantime having traveled through a path according to the variation continuously proceeding in the reduction of the blank from the feed to the finishing-point. From the point y the "path" may be said to widen, for the relative eccentricity of the circle described by the knives and that described by the spindle-centers diverges, thereby causing the latter to recede from the knives and carry the finished blank away from the action thereof as it proceeds to the initial end of the cam-guide which, as hereinbefore described, frees it from the spindles, the strippers l^2 only performing their function in case of sticking of the blank, which drops out of the machine as soon as freed. As will be understood, the turning of the feed-mechanism with relation to the revolution of the spindle-carrying gears B² is such as to push a blank into position to be gripped by the pair of spindles next in order to engage it, so that when the machine is in operation, so long as the supply of blanks is maintained to the feed-hopper, as many finished broom-handles will be turned out with each complete revolution of the gears B² as there are pairs of the spindles.

What I claim as new and desire to secure by Letters Patent is--

1. In a lathe the combination with the rotary knives, of the rotary spindle-supports permanently adjusted eccentrically with relation to the cutter-axis and carrying the radially disposed spindles, operated to rotate the blanks on their own axes and describing at their centers, by the said eccentricity, a circular path inclining toward the knives from one side to another of the machine, substantially as and for the purpose set forth.

2. In a lathe the combination with the rotary knives, of the rotary spindle-supports eccentrically adjusted with relation to the cutter-axis and carrying the radially disposed spindles operated to rotate the blanks on their own axes and describing at their centers, by the said eccentricity, a circular path inclining toward the knives from one side to

another of the machine, and a steady-rest for the blanks conforming on its bearing side to the exterior contour of the path described by a blank while undergoing reduction, substantially as and for the purpose set forth.

3. In a lathe the combination of a rotary shaft carrying the knives in a circle concentric with the said shaft, rotary spindle-supports permanently adjusted eccentrically with relation to the cutter-axis and actuated independently thereof, spindles radially disposed on the said supports to describe at their centers, by the said eccentricity, a circular path inclining toward the knives from one side to another of the machine, and operated to rotate the blanks on their own axes, and a feed for the blanks actuated from the spindle-support driving-mechanism, substantially as and for the purpose set forth.

4. In a lathe the combination of a rotary shaft carrying the knives in a circle concentric with the said shaft, rotary spindle-supports eccentrically adjusted with relation to the cutter-axis and actuated independently thereof, spindles radially disposed on the said supports to describe at their centers, by the said eccentricity, a circular path inclining toward the knives from one side to another of the machine and operated to rotate the blanks on their own axes, a steady-rest for the blanks conforming on its bearing-side to the exterior contour of the path described by a blank while undergoing reduction, and a feed for the blanks actuated from the spindle-support driving-mechanism, substantially as and for the purposes set forth.

5. In a lathe the combination with the frame A of a cutter-shaft A' having the knives radially supported upon it to describe a circle concentric with the shaft and journaled in adjustable bearings D, rotary gear-wheels B² supported on stationary bearings eccentrically surrounding the cutter-shaft and actuated independently thereof, and live-spindles C and dead-spindles C' supported, respectively, on the said gear-wheels to extend across the plane of their rotation in pairs on the two gear-wheels and disposed to describe at their centers, by the said eccentricity, a circular path inclining toward the knives from one side to another of the machine, substantially as and for the purpose set forth.

6. In a lathe the combination with the frame A of a rotary cutter-shaft A' having the knives radially supported upon it to describe a circle concentric with the shaft, rotary gear-wheels B² supported on stationary bearings eccentrically surrounding the cutter-shaft and actuated independently thereof, live-spindles C and dead-spindles C' supported, respectively, on the said gear-wheels to extend across the planes of their rotation in pairs on the two gear-wheels and disposed to describe at their centers by the said eccentricity, a circular path inclining toward the knives from one side to another of the machine, and a steady-rest M for the blanks ex-

tending from one side of the machine nearly to the feed at the opposite side thereof and conforming at its bearing side to the exterior contour of the path described by a blank in undergoing reduction, substantially as and for the purpose set forth.

7. In a lathe the combination with the frame, the cutter-carrying shaft the rotary spindle-supports carrying the radially disposed live and dead spindles and surrounding and driven independently of the cutter-shaft, of a feed I comprising a hopper g for the blanks open at its base and provided at opposite sides with clamping-springs f^2 and in advance thereof with seating-spring f^3 , eccentrics h on a counter-shaft k driven by the spindle-support actuating-mechanism, and pushers h^2 confined in guides and connected with the said eccentrics to be reciprocated horizontally across the open base of the hopper, substantially as and for the purpose set forth.

8. In a lathe the combination with the frame A of a rotary cutter-shaft A' having the knives radially supported upon it to describe a circle concentric with the shaft, rotary gear-wheels B^2 supported on stationary bearings B and B' eccentrically surrounding said shaft and actuated independently thereof, live-spindles C and dead-spindles C' supported, respectively, on the said gear-wheels to extend across the planes of their rotation in pairs on the two gear-wheels and disposed to describe at their centers, by the said eccentricity, a circular path inclining toward the knives from one side to another of the machine, a steady-rest M for the blanks, extending from one side of the machine nearly to the feed at the opposite side thereof and conforming at its bearing side to the exterior contour of the path described by a blank in undergoing reduction, and a feed comprising a hopper g for the blanks, a counter-shaft k carrying eccentrics h and driven by the spindle-support driving-mechanism, pushers h^2 connected with the eccentrics to be reciprocated across the open base of the hopper, clamping-springs f^2 at the opposite sides of the hopper and seating springs f^3 in advance thereof, for the blanks, substantially as and for the purpose set forth.

9. In a lathe the combination with the frame A of a rotary cutter-shaft A' having

the cutters radially supported upon it to describe a circle concentric with the shaft, rotary gear-wheels B^2 supported on stationary bearings B and B' eccentrically surrounding said shaft and actuated independently thereof, live-spindles C and spring-controlled dead-spindles C' supported, respectively, on the said gear-wheels to extend across the planes of their rotation in pairs on the two gear-wheels and disposed to describe at their centers, by the said eccentricity, a circular path inclining toward the knives from one side to another of the machine, a feed, and a cam-guide L for the dead-spindles terminating near the feed, substantially as and for the purpose set forth.

10. In a lathe the combination with the frame A of a rotary cutter-shaft A' having the cutters radially supported upon it to describe a circle concentric with the shaft, rotary gear-wheels B^2 supported on stationary bearings B and B' eccentrically surrounding said shaft and actuated independently thereof, live-spindles C and spring-controlled dead-spindles C' supported, respectively, on the gear-wheels B and B' to extend across the planes of their rotation in pairs on the two gear-wheels and disposed to describe at their centers, by the said eccentricity, a path narrowing toward the cutters from one side to another of the machine, a steady-rest M for the blanks, extending from one side of the machine nearly to the feed at the opposite side thereof and conforming at its bearing side exterior contour of the path described by a blank in undergoing reduction, a feed I comprising a hopper g for the blanks, a counter-shaft k carrying eccentrics h and driven by the spindle-support driving-mechanism, pushers h^2 connected with the said eccentrics to be reciprocated across the open base of the hopper, clamping-springs f^2 at the opposite sides of the hopper and seating-springs f^3 in advance thereof, for the blanks, and a cam-guide L in the path of the dead-spindles and terminating at its forward end adjacent to a clamping-spring f^2 , the whole being constructed and arranged to operate substantially as described.

HORACE W. TINGLEY.

In presence of—

J. W. DYRENFORTH,

M. J. FROST.